



**BTU Series**

**Electric Unit Heaters**

**BRASCH**

## unit heater applications

For primary or supplementary heating of entryways, storerooms, kitchens, garages, shipping rooms, warehouses, factories, hangers, power generating plants, pump houses and stores.

Eliminates piping, valves, traps, freeze ups, water leaks, vagrant heat waste, vents, stacks, gas piping and pilot lights.

## CONSTRUCTION DETAILS

BTU Series – Covers ranges from 2.5 KW through 50 KW. Fabricated from heavy gauge steel, plate fin elements, enclosed fan motor and adjustable louvers. Suitable for ceiling or wall mounting for horizontal or vertical down airflow. BTU Series offer great flexibility in control and construction options.

## BTU HEATERS

1. Heavy Duty Construction – Cabinets are made of heavy gauge steel for durability and trouble-free operation.
2. Supply Connection – Single connection eliminates separate fan motor circuit.
3. Motor – Fan motors have built-in automatic reset thermal overload protection. Motor is ventilated with unheated air.
4. Service Compartment – Hinged service door allows easy access to line terminals, fuses, contactors and transformers.
5. Louvers – Each louver is adjustable for positive control of discharge air.
6. Housing – Contemporary styling with tough, durable neutral gray oven baked finish resists corrosion and assures long life.
7. Thermostat – Optional adjustable built-in thermostat.
8. Mounting – Recessed fasteners on top and back of housing for threaded rod hangers are standard, allowing either horizontal or vertical airflow. Optional combination ceiling or wall mounted swivel brackets allow up to 180° adjustment of discharge air direction.
9. Plate Fin Elements – Copper plated steel tubular elements are brazed to multiple fins for high strength and heat dissipation. Elements are protected against corrosion by high temperature paint. An automatic reset thermal cutout protects the heater elements.
10. NEMA-12 Terminal Box – Optional on all BTUs. UL listed through 50 KW units.

## energy savers

**Thermostatic Fan Switch** – Built into each unit, dissipates residual heat to re-circulate ambient air until temperature drops to 90° F.

**Two Step Control** – Provides smaller KW steps for finer control and lower operating cost (standard on some models).

**Econowatt** – On first call for heat, fan circulates warm air from ceiling to floor without element heat; a second call for heat, energizes elements. Fan continues to circulate residual element heat after thermostat has been satisfied.

## built-in controls

**Magnetic Control Contactor** – Disconnecting break contactors are provided as standard unless heater is single phase and operated by a load-carrying thermostat.

**Sub-circuit Fusing** – When heater ampacity exceeds 48 amps, built-in sub-circuit fuses are supplied to meet the National Electrical Code.

**Fan Delay** – Dissipates all residual heat from elements and re-circulates entering ambient air until temperature drops to 90° F for maximum energy conservation.

**Motor Over-current Protection** – Motor fusing is built into heaters over 40 amps when the motor is greater than 1/8 HP. All units incorporating a step-down transformer to drive the fan motor have built-in transformer primary fusing.

**Control Transformer** – 24V control is standard on BTU models at 480 or 600 volts. May be optional on all other models.

**Disconnect Switch** – Optional. Non-fused and mechanically interlocked with terminal box door to prevent access unless power is removed. Meets NEC requirements. UL listed and factory installed.

**SCRs** – Provide the finest in electric heat control. SCR units include back to back SCRs, solid state firing circuit and aluminum heat sinks. The heat sink, electrically insulated from live parts, is mounted outside the terminal box, maximizing convection cooling. Power and heat outputs are precisely controlled from zero to 100% in direct proportion to thermostat requirements. Fan control remains completely independent. SCRs are UL Listed.

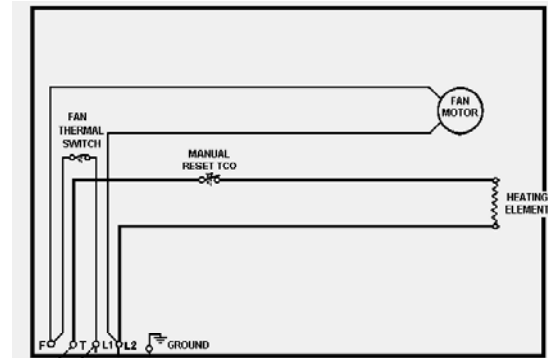

FIGURE 2: 240 V, Single Phase, 3KW Circuit Diagram

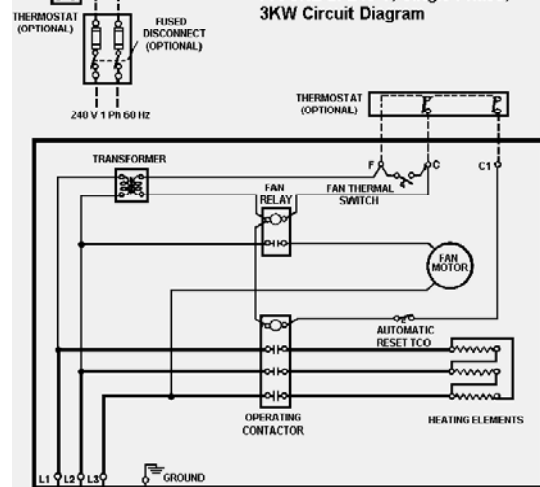

FIGURE 3: 480V, Three Phase, 10 KW Circuit Diagram with 24 volt control

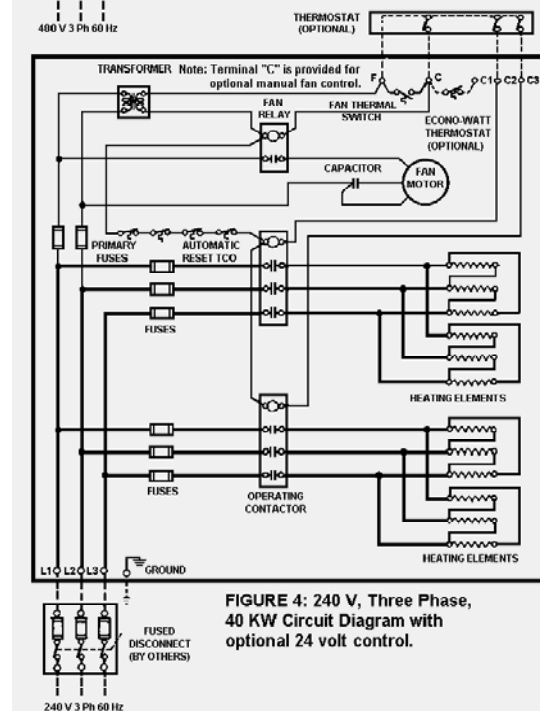

FIGURE 4: 240 V, Three Phase, 40 KW Circuit Diagram with optional 24 volt control.

## Sample Specification

1. Furnish and install Brasch UL listed BTU (2.5 to 50 KW) unit heaters with voltage, phase, number of steps, heating and air delivery capacities as scheduled. Units shall be universally suitable for vertical and horizontal mounting.
2. Unit heater(s) shall be draw-thru design to provide uniform temperature across heater element and forced air cooling of motor with ambient air.
3. Heater elements shall be corrosion protected, steel tubular sheath elements with elements brazed to fins for maximum strength and heat transfer. Contactor, where required, shall provide disconnecting line break. Provide automatic or manual reset thermal cutouts to protect from over-temperature.
4. All motors shall be enclosed, have permanently lubricated bearings and built-in thermal protection. A separate motor supply circuit shall not be required.
5. All units to have a single supply circuit with fuses as required by NEC for element and motor protection.
6. Fans shall be aluminum, directly connected to the fan motor. All units shall have a thermal fan delay switch to prevent blowing of unheated air and to remove residual heat from cabinet by re-circulating ambient air until temperature drops to 90° F. for maximum energy savings. An enamel paint finish shall protect all metal cabinet surfaces.
7. Brackets shall be furnished for wall or ceiling mounting where shown on heater schedule.
8. Individually adjustable louvers shall be furnished to direct discharge air as desired. Optional down-flow diffusers shall be provided where shown on schedule (specify radial, cone or four-way adjustable louver).
9. Thermostat shall be provided where shown on schedule (specify built-in or remote room thermostat).
10. Other options provided shall include:
  - 24 Volt control (where not standard).
  - Two step control (where not standard).
  - Summer/Winter switch for ventilation only.
  - Interlocking, non-fused disconnect switch.
  - Heating/Cooling thermostat with fan switch sub-base.
  - Night setback thermostat
  - Anti-bird screen
  - Econowatt energy saving circuit.
  - Manual reset thermal cutout (in addition to automatic –consult factory).
  - SCR (solid state modulating control).
  - NEMA-12 terminal box enclosure. (UL listed through 50 KW).
11. Manufacturer shall provide one year limited warranty against defects in workmanship or materials.

**TABLE 1: DIMENSIONS (inches)**

KW	3-10	12.5-20	25-50
A	18 1/2	22 1/4	27 1/4
B	14	17	21
C	11 1/2	15 1/4	22 1/4
D	7	6	6
E	8	6	12
F	4	4	4
H	-	26 1/4	35 1/4
J	-	26	31
V	-	15	16
W	-	17	22 1/2
X	-	6	8 1/2
Y	-	1	2 1/2

Refer to figures 5, 6 and 7

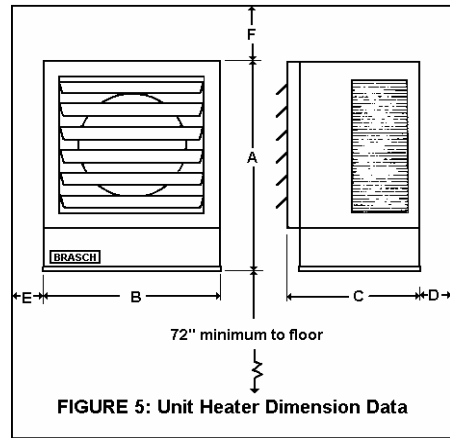

**TABLE 2: SPECIFICATIONS**

MODEL NUMBER	ELECTRICAL ( 60 Hz )								AIRFLOW					STANDARD BUILT IN CONTROL FEATURES		MOUNTING HEIGHT (FT)		SHIPPING WEIGHTS		FIELD WIRES
	HEATER				MOTOR				FAN DIA.	CFM @70°F	OUTLET VELOCITY (FPM)	TEMP RISE °F	THROW (FEET)	NEC FUSES - CONTACTORS - TRANSFORMER	CNTRL VOLTS	DISCHARGE		LBS	KGMS	CU AWG
	KW	BTU /HR	VOLTS /PH	AMPS	STEPS	VOLTS /PH	HP	AMPS								HORIZ	VERT			
BTU-2.5-2081	2.5	8550	208/1	12.0	1	208/1	1/20	0.9	12	350	425	23	13	N/A - N/A - N/A	208	7.5	9	54	24	2-#12
BTU-2.5-2041	2.5	8550	240/1	10.0	1	240/1	1/20	1.1	12	350	425	23	13	N/A - N/A - N/A	240	7.5	9	54	24	2-#14
BTU-2.5-2771	2.5	8550	277/1	9.0	1	277/1	1/20	0.8	12	350	425	23	13	N/A - N/A - N/A	277	7.5	9	54	24	2-#14
BTU-5.0-2081	5.0	17100	208/1	24.0	1	208/1	1/20	0.9	12	500	625	32	18	N/A - N/A - N/A	208	8	10	54	24	2-#10
BTU-5.0-2401	5.0	17100	240/1	21.0	1	240/1	1/20	1.1	12	500	625	32	18	N/A - N/A - N/A	240	8	10	54	24	2-#10
BTU-5.0-2771	5.0	17100	277/1	18.0	1	277/1	1/20	0.8	12	500	625	32	18	N/A - N/A - N/A	277	8	10	54	24	2-#10
BTU-5.0-2083	5.0	17100	208/3	14.0	1	208/3	1/20	0.9	12	500	625	32	18	N/A - 1 - N/A	208	8	10	55	25	3-#12
BTU-5.0-2403	5.0	17100	240/3	12.1	1	240/3	1/20	1.1	12	500	625	32	18	N/A - 1 - N/A	240	8	10	55	25	3-#12
BTU-5.0-4803	5.0	17100	480/3	6.0	1	480/1	1/20	0.41	12	500	625	32	18	N/A - 1 - YES	24	8	10	57	26	3-#14
BTU-5.0-6003	5.0	17100	600/3	5.0	1	240/1	1/20	1.00	12	500	625	32	18	N/A - 1 - YES	24	8	10	71	32	3-#14
BTU-7.5-2081	7.5	25650	208/1	36.0	1	208/1	1/20	0.9	12	750	935	32	22	N/A - 1 - N/A	208	9	13	55	25	2-#6
BTU-7.5-2401	7.5	25650	240/1	31.0	1	240/1	1/20	1.1	12	750	935	32	22	N/A - 1 - N/A	240	9	13	55	25	2-#6
BTU-7.5-2771	7.5	25650	277/1	27.0	1	277/1	1/20	0.8	12	750	935	32	22	N/A - 1 - N/A	277	9	13	55	25	2-#8
BTU-7.5-2083	7.5	25650	208/3	21.0	1	208/1	1/20	0.9	12	750	935	32	22	N/A - 1 - N/A	208	9	13	55	25	3-#10
BTU-7.5-2403	7.5	25650	240/3	18.0	1	240/1	1/20	1	12	750	935	32	22	N/A - 1 - N/A	240	9	13	55	25	3-#10
BTU-7.5-4803	7.5	25650	480/3	9.0	1	480/1	1/20	0.4	12	750	935	32	22	N/A - 1 - YES	24	9	13	57	26	3-#14
BTU-7.5-6003	7.5	25650	600/3	7.0	1	240/1	1/20	1.1	12	750	935	32	22	N/A - 1 - YES	24	9	13	71	32	3-#14
BTU-10-2081	10.0	34200	240/1	48.0	1	208/1	1/10	1.6	12	870	1090	36	26	N/A - 1 - N/A	208	10	14	60	27	2-#6
BTU-10-2401	10.0	34200	240/1	42.0	1	240/1	1/10	1.6	12	870	1090	36	26	N/A - 1 - N/A	240	10	14	60	27	2-#6
BTU-10-2083	10.0	34200	208/3	24.1	1	208/1	1/10	1.6	12	870	1090	36	26	N/A - 1 - YES	24	10	14	79	36	3-#8
BTU-10-2403	10.0	34200	240/3	24.1	1	240/1	1/10	1.6	12	715	980	44	21	N/A - 1 - YES	24	9	12	42	19	3-#8
BTU-10-4803	10.0	34200	480/3	12.1	1	240/1	1/10	0.71	12	715	980	44	21	N/A - 1 - YES	24	9	12	42	19	3-#12
BTU-10-6003	10.0	34200	600/3	10.0	1	480/1	1/10	1.6	12	715	980	44	21	N/A - 1 - YES	24	9	12	42	19	3-#14
BTU-12.5-2083	12.5	42750	208/3	35.0	1	208/1	1/10	1.6	12	870	1110	46	26	N/A - 1 - N/A	208	10	14	65	29	3-#6
BTU-12.5-2403	12.5	42750	240/3	30.0	1	240/1	1/10	1.6	12	870	1110	46	26	N/A - 1 - N/A	240	10	14	65	29	3-#8
BTU-12.5-4803	12.5	42750	480/3	15.0	1	480/1	1/10	0.71	12	870	1110	46	26	N/A - 1 - YES	24	10	14	72	32	3-#12
BTU-12.5-6003	12.5	42750	600/3	12.0	1	240/1	1/10	1.6	12	870	1110	46	26	N/A - 1 - YES	240	10	14	69	31	3-#14
BTU-15-2083	15.0	51300	208/3	42.0	1	208/1	1/4	1.78	12	1250	1575	38	33	N/A - 1 - N/A	208	11	21	61	28	3-#6
BTU-15-2403	15.0	51300	240/3	36.0	1	240/1	1/4	2.04	12	1250	1575	38	33	N/A - 1 - N/A	240	11	21	61	28	3-#6
BTU-15-4803	15.0	51300	480/3	18.0	1	480/1	1/4	1.1	12	1250	1575	38	33	N/A - 1 - YES	24	11	21	73	33	3-#10
BTU-15-6003	15.0	51300	600/3	14.0	1	240/1	1/4	2.04	12	1250	1575	38	33	N/A - 1 - YES	24	11	21	80	36	3-#12
BTU-20-2083	20.0	68400	208/3	56.0	2	208/1	1/4	1.78	12	1250	1615	51	33	6 - 2 - N/A	208	11	21	64	29	3-#3
BTU-20-2403	20.0	68400	240/3	48.0	1	240/1	1/4	2.04	12	1250	1615	51	33	N/A - 1 - N/A	240	11	21	61	28	3-#4
BTU-20-4803	20.0	68400	480/3	24.0	1	480/1	1/4	1.1	12	1250	1615	51	33	N/A - 1 - YES	24	11	21	80	36	3-#8
BTU-20-6003	20.0	68400	600/3	19.0	1	240/1	1/4	2.04	12	1250	1615	51	33	N/A - 1 - YES	24	11	21	87	39	3-#10
BTU-25-2083	25.0	85500	208/3	69.0	2	208/1	1/4	1.78	16	2500	1715	32	48	6 - 2 - N/A	208	13	26	104	47	3-#2
BTU-25-2403	25.0	85500	240/3	60.0	2	240/1	1/4	2.04	16	2500	1715	32	48	6 - 2 - N/A	240	13	26	104	47	3-#3
BTU-25-4803	25.0	85500	480/3	30.0	1	480/1	1/4	1.1	16	2500	1715	32	48	N/A - 1 - YES	24	13	26	117	53	3-#8
BTU-25-6003	25.0	85500	600/3	24.0	1	240/1	1/4	2.04	16	2500	1715	32	48	N/A - 1 - YES	24	13	26	128	58	3-#10
BTU-30-2083	30.0	102600	208/3	83.0	2	208/1	1/4	1.78	16	2500	1735	38	48	6 - 2 - N/A	208	13	26	120	55	3-#2
BTU-30-2403	30.0	102600	240/3	72.0	2	240/1	1/4	2.04	16	2500	1735	38	48	6 - 2 - N/A	240	13	26	120	55	3-#2
BTU-30-4803	30.0	102600	480/3	36.0	1	480/1	1/4	1.1	16	2500	1735	38	48	N/A - 1 - YES	24	13	26	133	60	3-#6
BTU-30-6003	30.0	102600	600/3	29.0	1	240/1	1/4	2.04	16	2500	1735	38	48	N/A - 1 - YES	24	13	26	144	65	3-#8
BTU-40-2083	37.5	128250	208/3	104.0	2	208/1	1/4	1.78	16	2500	1780	48	48	9 - 3 - N/A	208	13	26	122	55	3-#0
BTU-40-2403	40.0	136800	240/3	96.0	2	240/1	1/4	2.04	16	2500	1790	51	48	6 - 2 - N/A	240	13	26	120	55	3-#1
BTU-40-4803	40.0	136800	480/3	48.0	1	480/1	1/4	1.1	16	2500	1790	51	48	N/A - 1 - YES	24	13	26	133	60	3-#4
BTU-40-6003	40.0	136800	600/3	37.0	1	240/1	1/4	2.04	16	2500	1790	51	48	N/A - 1 - YES	24	13	26	144	65	3-#6
BTU-50-2083	50.0	171000	208/3	139.0	2	208/1	1/4	1.78	16	2500	1800	63	48	12 - 4 - N/A	208	13	26	121	58	3-#00
BTU-50-2403	50.0	171000	240/3	120.0	2	240/1	1/4	2.04	16	2500	1800	63	48	9 - 3 - N/A	240	13	26	122	55	3-#00
BTU-50-4803	50.0	171000	480/3	60.0	2	480/1	1/4	1.1	16	2500	1800	63	48	6 - 2 - YES	24	13	26	136	61	3-#3
BTU-50-6003	50.0	171000	600/3	48.0	2	240/1	1/4	2.04	16	2500	1800	63	48	N/A - 2 - YES	24	13	26	142	66	3-#4

**ul listing**

BTU Electric Unit Heaters are UL listed under File No. E61887

**how to order**

- Specify:
1. Model Number
  2. Accessories
  3. Thermostat

**notes**

- Specifications are subject to change without notice
- ① All one step units 3.7 KW and larger are optionally available with 2 steps
  - ② All motors are 1550 RPM
  - ③ Throw is the distance air moves until it's velocity reduces to 50 fpm.
  - ④ Based on 60° ratings. Copper wire only.

## application tips

**Limitations** – Unit heaters shall not be used in potentially explosive atmospheres, nor should they be located where obstructions might block air inlet, motor cooling vents or discharge.

**Applications** – Larger rooms require multi-unit installations. Arrange units to provide perimeter air circulation.

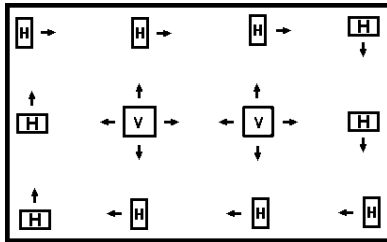

Figure 8

To prevent air stratification, the total CFM capacity of all units should circulate the room air volume at least three times per hour.

Unit heaters should be located so their air streams wipe exposed walls without blowing directly at them. In multi-unit installations, it is good practice to locate units so each supports the air stream of another, thus setting up a circulatory air movement within the space. Distance between unit heaters should not be less than the throw of one heater nor more than twice its throw; for throw data see Table 2. For interior spaces and high bay areas, additional unit heaters mounted vertically can be used. In warehouse type applications where maintaining minimum temperatures is the basic requirement, one or more large unit heaters can be used in order to reduce initial installation expense.

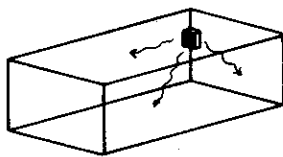

Figure 9

One unit heater can heat small rooms. Where two walls are exposed, the heater should be mounted as shown in figure 9.

For individual spaces, total heating capacity is calculated in the conventional way, using formulas in the ASHRAE guide.

When heating capacity for a pedestrian entryway is unknown, a rule of thumb of 4000 watts per door can be used.

Unit heaters are frequently used to combat cold air inrush when loading dock doors are opened. For such applications, one or more units should be arranged to blow warm air across the opening, not toward it.

## mounting arrangements

Any Brasch unit heater can be mounted in either a horizontal or vertical discharge position.

**Horizontal Discharge** – Heaters can be mounted horizontally using the optional swivel and wall mounting brackets.

The swivel bracket allows heater to be rotated to face various directions and can be ordered separately for use as a ceiling bracket. The wall mounting bracket provides for minimum spacing requirements in all directions. A threaded bolt with lock nut attaches the swivel bracket to the wall bracket. The wall bracket attaches to the wall using SAE grade 5, 1/2-13NC bolts and nuts. Bolts and nuts are provided as part of the wall mount and swivel bracket kits. BTUs may also be mounted horizontally using four 1/2-13NC threaded steel rods.

**Vertical Discharge** – Heaters are mounted vertically using four threaded steel rods. Four threaded holes are provided in the heater. Additional mounting hardware, if required, is supplied by the installer. See Table 3 for coverage.

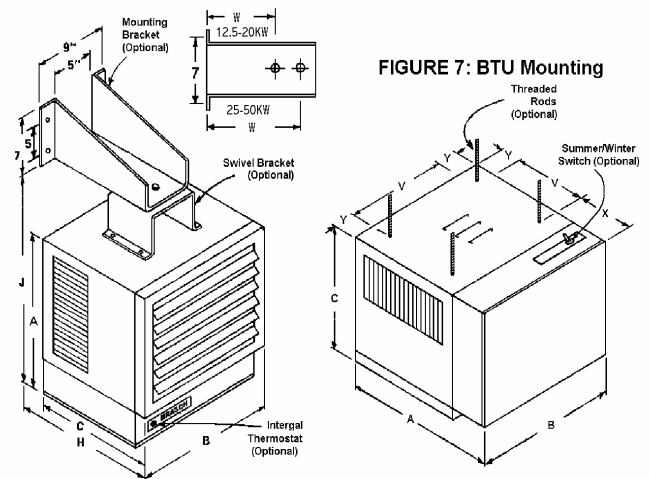
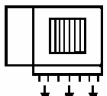
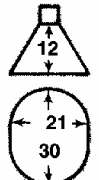
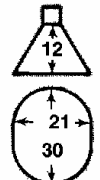
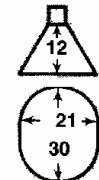
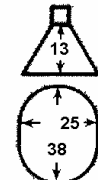
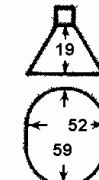
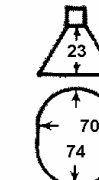
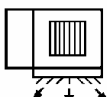
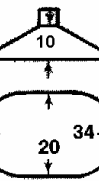
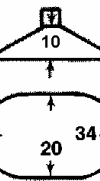
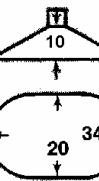
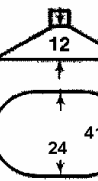
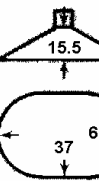
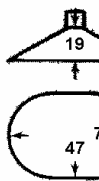
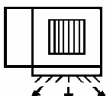
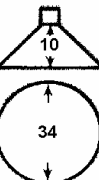
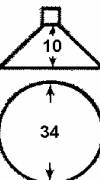
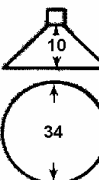
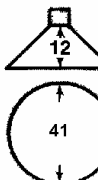
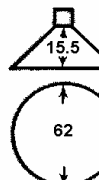
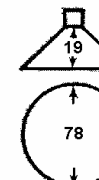
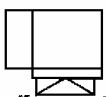
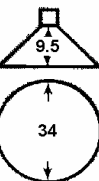
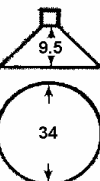
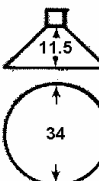
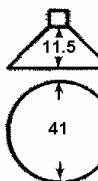
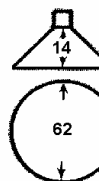
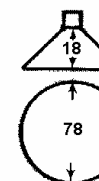
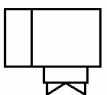
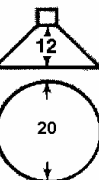
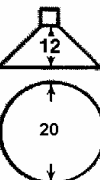
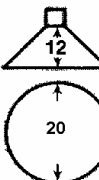
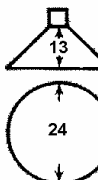
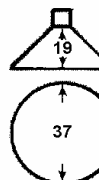
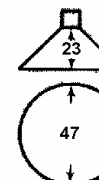
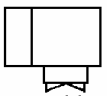
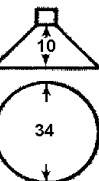
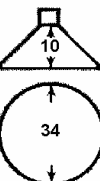
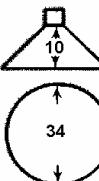
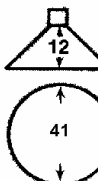
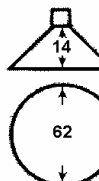
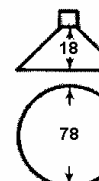

FIGURE 7: BTU Mounting

**TABLE 3: AIR DISTRIBUTION PATTERNS (VERTICAL DISCHARGE)**

**APPROXIMATE MOUNTING HEIGHT AND FLOOR COVERAGE (FEET)**

KW	3	5	7.5	10	15 - 20	25 - 50
 STANDARD LOUVERS (0°)						
 STANDARD LOUVERS (45°)						
 FOUR WAY LOUVERS (45°)						
 CONE DIFFUSER						
 RADIAL DIFFUSER (0°)						
 RADIAL DIFFUSER (45°)						

Note: Height is based upon optimum floor coverage with 50 fpm velocity four feet above the floor. Specific boundary pattern is dependent upon obstacles, drafts and mounting arrangements. Drawings are not to scale.

## Accessories for BTU Series Heaters

**TABLE 4: TEMPERATURE CONTROL KITS\* AND OPTIONS**

CAT. NO.	MOUNTING	RANGE	DUTY	RATINGS	FEATURES
TK-1	Intergal	40-100 F	Line / Pilot	24-277V	SPST Thermostat Kit
TK-2	Intergal	40-100 F	Line / Pilot	24-277V	DPST Thermostat Kit
TK-3	Intergal / Wall	40-100 F	Line / Pilot	24-277V	2 Stage, 2-SPST Thermostat Kit with 'Off'
TK-11	Intergal	Sum./Wint.	Pilot	24-277V	Summer Ventilation Override Switch
TK-16	Intergal	40-100 F	Pilot	24-277V	Econowatt Thermostat Kit - Use with 2 Stage Wall
Suffix-FM	Intergal				Factory Mounted Thermostat Kit
Suffix-24	Intergal		Low Volt	24V	Convert 208, 240 or 277V control to 24V
Suffix-2S	Intergal	above 3KW	Two Stage		Convert 1 Step Heater to 2 Steps
Suffix-MR	Unit Rear				Add Manual Reset Thermal Cutout
Suffix-RC	Wall - Remote				UL listed Remote Control Panel
Suffix-N12A	Intergal		UL	Up to 20 KW	Dusttight NEMA-12 Terminal Box
Suffix-N12B	Intergal		Not UL	From 25-50KW	Dusttight NEMA-12 Terminal Box
Suffix-DS	Intergal		UL / NEC		Non-fused Interlocking Disconnect Switch
Suffix-SCR	Intergal				Modulating SCR control**

\*Consult factory or representative for variety of remote thermostats.

\*\*Consult factory on UL listing.

**TABLE 5: DIFFUSER KITS AND SCREENS**

CAT. NO.	USE WITH	DESCRIPTION
CD-1	UP to 20KW	Diffuser Kit, Cone Type for Vertical Discharge
CD-2	From 25-50KW	Diffuser Kit, Cone Type for Vertical Discharge
LD-1	UP to 20KW	Diffuser Kit, Four-Way Louvers
LD-2	From 25-50KW	Diffuser Kit, Four-Way Louvers
RD-1	UP to 20KW	Diffuser Kit, Radial Type for Vertical Discharge
RD-2	From 25-50KW	Diffuser Kit, Radial Type for Vertical Discharge
AS-1	UP to 20KW	Anti-Bird Screen, Meets OSHA requirements, Factory Mounted
AS-2	From 25-50KW	Anti-Bird Screen, Meets OSHA requirements, Factory Mounted

**TABLE 6: MOUNTING HARDWARE KITS**

CAT. NO.	USE WITH	DESCRIPTION
WB-1	BTU	Wall Mount Assembly Kit for Horizontal Discharge - Wall and swivel Brackets
SB-1	BTU	Ceiling Mount Swivel Bracket Kit for Horizontal Discharge
TR-1	BTU	Rod Hanger Kit - Four 1/2"-13x24" Threaded Rods

