



## **Brasch Wall Heaters**

# BRASCH Architectural Forced Air WALL Heaters

## Decorator Designed for Functional Beauty and Versatility

**Rugged Grille:** Heavy dark brown 18 gauge steel grille.

**Richly Styled Grille:** Grille is highlighted by a 14-gauge anodized extruded aluminum frame.

**Electric Element:** Steel sheath with plate heat exchanger.

**Fan Delay Switch:** Allows fan to continue to run for a short period after thermostat is satisfied to expel warm air from inside heater, also delays fan on start up to insure delivery of heated air.

**Unique Vane Axial Fan Wheel** draws in large volumes of air then quietly discharges heated air downward into room.

**Tamper Resistant Thermostat and Disconnect Switch** accessible through grille.

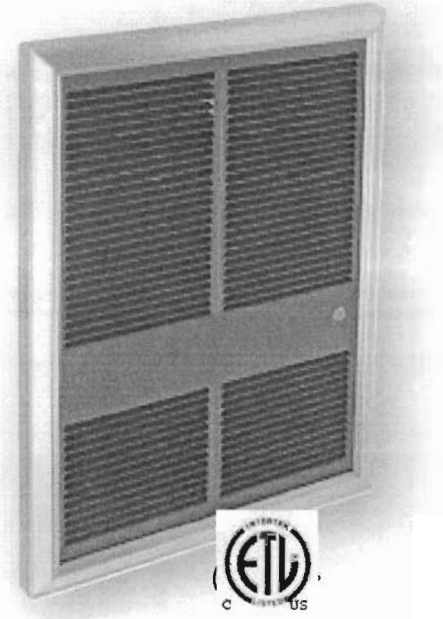

Specifications			
Model Number	Watts	Volts	Weight
BWH7512	750	120	22 lb.
BWH1012	1000	120	22 lb.
BWH1512	1500	120	26 lb.
BWH4020	4000	208	29 lb.
BWH4820	4800	208	29 lb.
BWH1524	1500/1125	240/208	26 lb.
BWH2024	2000/1500	240/208	27 lb.
BWH3024	3000/2250	240/208	29 lb.
BWH4024	4000/3000	240/208	29 lb.
BWH4824	4800	240	29 lb.
BWH1527	1500	277	26 lb.
BWH2027	2000	277	27 lb.
BWH3027	3000	277	29 lb.
BWH4027	4000	277	29 lb.
BWH4827	4800	277	29 lb.

Field Installed Accessories		
Model Number	Description	Weight
Box 3310	Rough-in Box Only (for advance installation)	10 lb.
3320EX33	Surface Mounting Adapter	1 lb.
3320EX16	2" Semi-recess Sleeve	1 lb.

Factory Installed Accessories	
Suffix	Description
R	Day Night Relay
HD	16 Ga. Steel Heavy Duty Grill

## Architectural Quality Wall Mounted

- Built-in disconnect switch
- Built-in tamper resistant thermostat
- Richly styled, rugged grille
- Whisper-quiet sound level
- Fan delay
- 1-Year element limited warranty
- ETL Semko Listed

## Typical Specifications

Brasch Heavy-Duty Forced Air Heaters shall be constructed of a heavy 18 gauge steel housing with an extruded aluminum frame. The rough-in dimensions are 19-5/16" high x 14-3/16" wide x 4" deep. The units shall be available in ratings from 750 to 1500 watts at 120 and 1500 to 4800 watts at 240, 208 and 277 volts. The heaters shall have a low-speed 600 RPM, 4-pole motor which drives a vane axial blower to deliver a quiet 175 CFM of down flow air. The heating element shall be of the sealed tubular type with large, parallel steel fins for quick heat transfer. Unit shall have as standard, a thermal overload cut-off for added safety, fan delay switch and a built-in tamperproof thermostat which shall be calibrated to provide a range of 55°F. to 85°F. and manual disconnect switch.

Optional accessories shall include a surface mounting adapter, day-night relays. All heaters shall be listed by ETL Semko. The heating element shall be supplied with a manufacturer's 1-year limited warranty.

**STANDARD  
HEATER  
WITH  
DISCONNECT  
SWITCH**

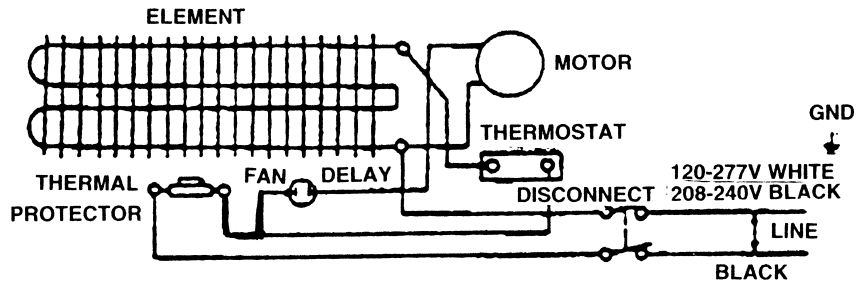

**OPTIONAL  
HEATER  
WITH  
DISCONNECT  
SWITCH AND  
DAY-NIGHT RELAY**

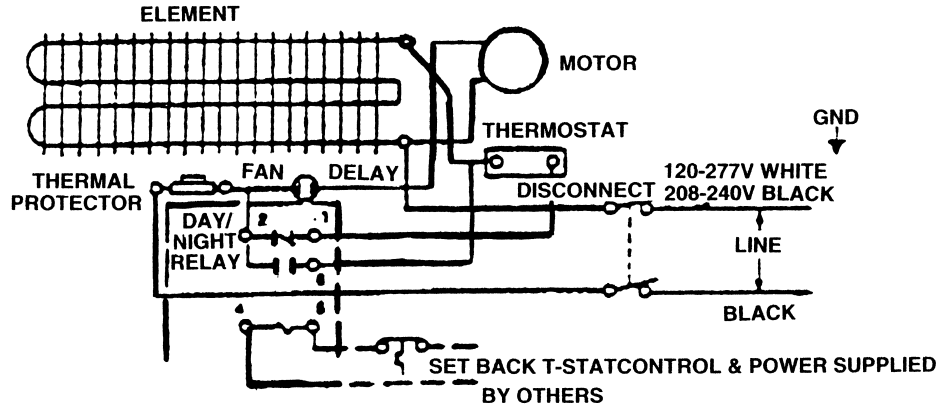

**Dimensions**

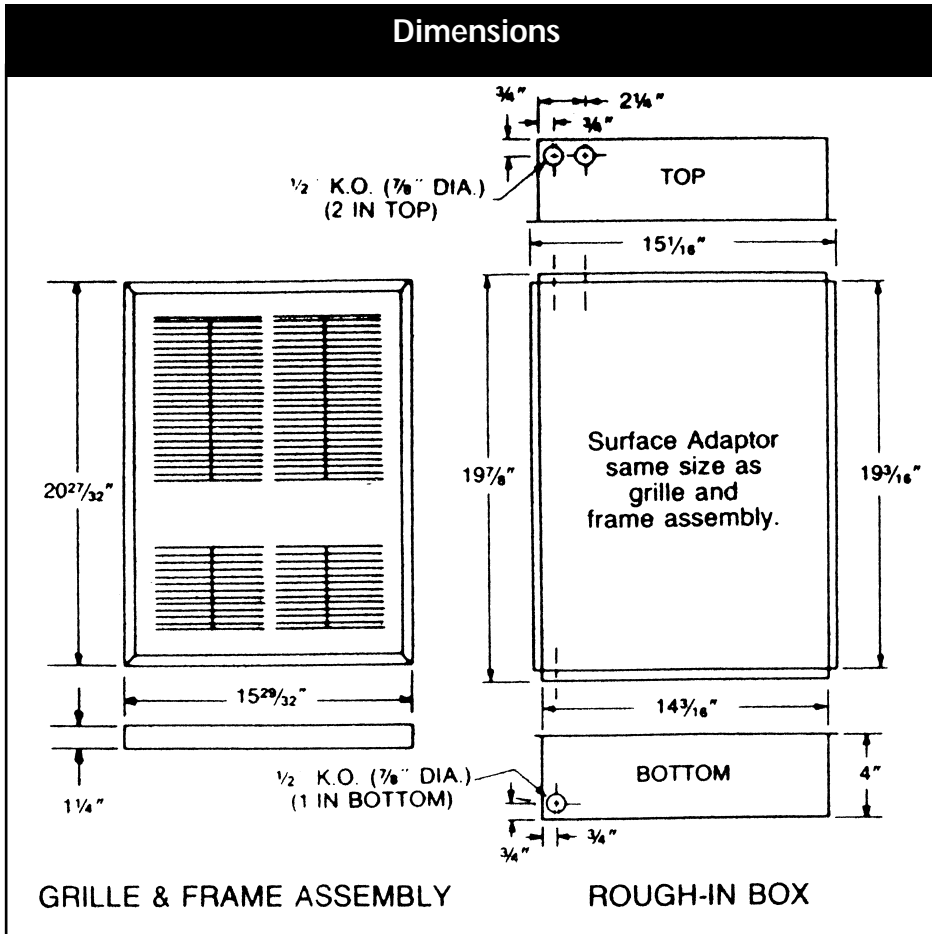

## Limited Warranty

All Brasch Manufacturing Company, Inc. products covered in this bulletin are warranted against defects in workmanship and materials for one year from date of purchase. This warranty does not apply to damage from accident, misuse or alteration; nor where the connected voltage is more than 5% above product nameplate voltage; nor to equipment improperly installed or wired or maintained in violation of installation instructions. This warranty is valid only in the fifty states of the United States. No other written or oral warranty applies. No employee, agent, dealer or other person is authorized to extend warranty on behalf of Brasch Manufacturing Company.

The customer shall be responsible for all costs incurred in the removal or reinstallation and shipping of the product for repairs. Inoperative units should be returned to Brasch, attention of Service Manager for repair or replacement at our option. Product will be returned freight prepaid. Repair or replacement is the exclusive remedy available from Brasch who is not liable for damages of any kind, including incidental and consequential damage.



**BRASCH**  
MANUFACTURING COMPANY, INC.

11880 Dorsett Road  
Maryland Heights, MO 63043

314.291.0440 • Fax 314.291.0646  
e-mail: [braschmfg@braschmfg.com](mailto:braschmfg@braschmfg.com)  
[www.braschmfg.com](http://www.braschmfg.com)

©Brasch Manufacturing Company, Inc.